

| REVISIONS |               |                   |                     |            |
|-----------|---------------|-------------------|---------------------|------------|
| REV. SYM. | E.C.O. NUMBER | DESCRIPTION       | BY DATE             | APP'D DATE |
| 6         |               | UPDATED GAGE INFO | K. KOONS<br>5.12.15 |            |

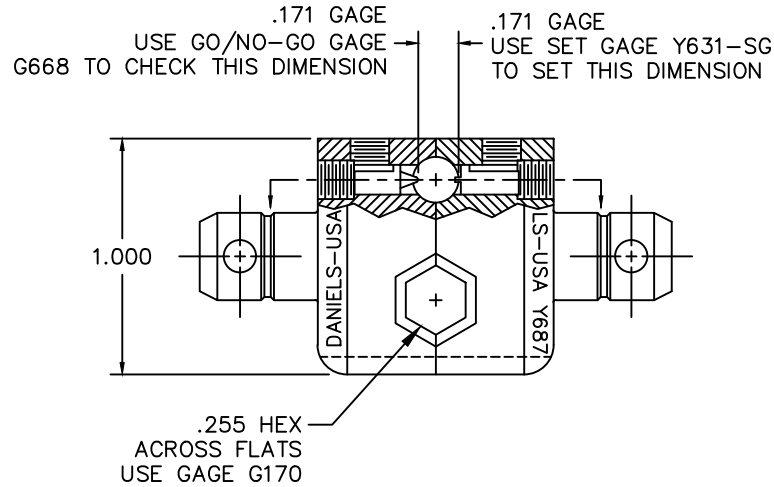
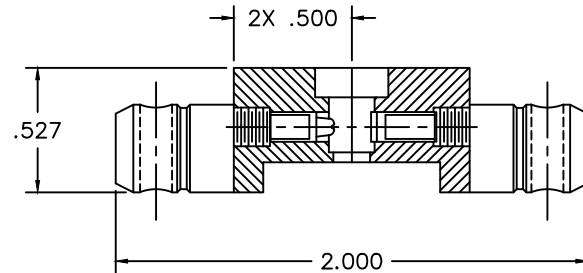

**UNCONTROLLED DOCUMENT  
WILL NOT BE UPDATED**  
DIMENSIONS IN INCHES - UNLESS OTHERWISE SPECIFIED

1. TROMPETER CD5-9.

NOTES:

|                                                                                                                                                                                                                                                                                                 |  |            |  |                                                                                                                                                     |               |          |                     |       |    |
|-------------------------------------------------------------------------------------------------------------------------------------------------------------------------------------------------------------------------------------------------------------------------------------------------|--|------------|--|-----------------------------------------------------------------------------------------------------------------------------------------------------|---------------|----------|---------------------|-------|----|
| <b>RESTRICTED &amp; CONFIDENTIAL</b>                                                                                                                                                                                                                                                            |  | MATERIAL   |  | ITEM                                                                                                                                                | PART NO.      | QTY.     | DESCRIPTION/REMARKS |       |    |
| CONFIDENTIAL PROPERTY OF DANIELS MANUFACTURING CORP. NOT TO BE DISCLOSED TO OTHERS, REPRODUCED OR USED FOR ANY OTHER PURPOSE, EXCEPT AS AUTHORIZED IN WRITING BY DANIELS MANUFACTURING. MUST BE RETURNED TO DANIELS MANUFACTURING CORP. ON COMPLETION OF ORDER OR OTHER PURPOSE FOR WHICH LENT. |  | HEAT TREAT |  | DRN.                                                                                                                                                | B. KILPATRICK | DATE     | 4-17-98             |       |    |
|                                                                                                                                                                                                                                                                                                 |  |            |  | CHK'D.                                                                                                                                              | DAD           | DATE     | 4-98                |       |    |
|                                                                                                                                                                                                                                                                                                 |  |            |  | APP'D.                                                                                                                                              |               | DATE     |                     |       |    |
|                                                                                                                                                                                                                                                                                                 |  |            |  | APP'D.                                                                                                                                              |               | DATE     |                     |       |    |
| DO NOT SCALE DRAWING                                                                                                                                                                                                                                                                            |  | FINISH     |  | NOTE:                                                                                                                                               |               |          |                     |       |    |
|                                                                                                                                                                                                                                                                                                 |  |            |  | THIS DRAWING IS AN OUTLINE DRAWING OF THE RESPECTIVE DMC PART NUMBER INDICATED. ACTUAL DMC PART NUMBER IS DRAWING NUMBER WITHOUT THE "-ENV" SUFFIX. |               |          |                     |       |    |
|                                                                                                                                                                                                                                                                                                 |  |            |  | WHERE USED:                                                                                                                                         | SIZE          | SCALE    | CAD P/N             | SHEET | OF |
|                                                                                                                                                                                                                                                                                                 |  |            |  | B                                                                                                                                                   | 2X            | Y687-ENV | 1                   | 1     |    |
|                                                                                                                                                                                                                                                                                                 |  |            |  | POSTING                                                                                                                                             | DWG. NO.      | REV.     |                     |       |    |
|                                                                                                                                                                                                                                                                                                 |  |            |  |                                                                                                                                                     | Y687-ENV      | 6        |                     |       |    |



DANIELS MANUFACTURING CORP.  
ORLANDO, FLORIDA  
CAGE 11851

TITLE  
DIE SET  
ENVELOPE DRAWING