

USERS MUST ENSURE CORRECT REVISION

REVISIONS				
REV. SYM.	E.C.O. NUMBER	DESCRIPTION	BY DATE	APP'D DATE
4		REVISED NOTE 1	K. KOONS 8.9.10	D. EBY 8.9.10
5		ADDED TOLERANCES	ENF 2-14-14	RRR 2-14-14

**UNCONTROLLED DOCUMENT  
WILL NOT BE UPDATED**

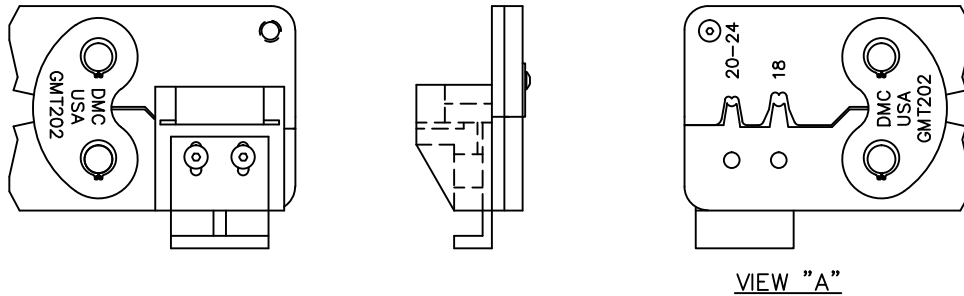
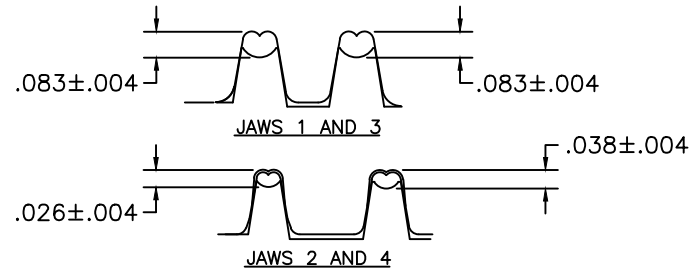
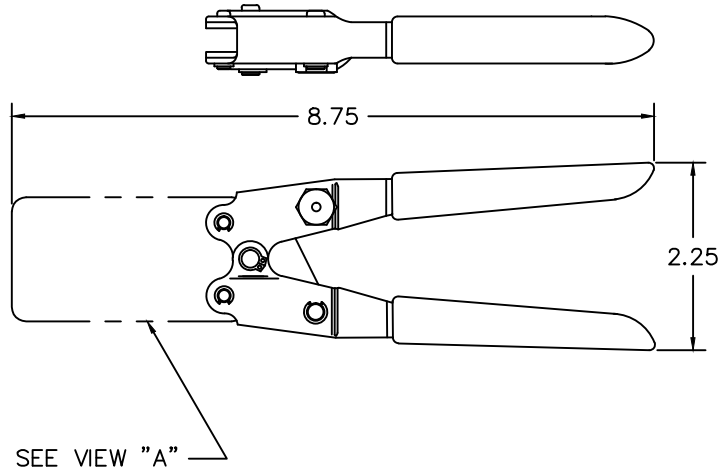

VIEW "A"

2. MOLEX HTR1719 EQUIVALENT.

1. FOR JAWS 1 & 3, CRIMP  $\phi$ .125, 50/50 SOLID SOLDER  
FOR JAWS 2 & 4, CRIMP  $\phi$ .062, 50/50 SOLID SOLDER  
AND MEASURE WITH A BLADE MICROMETER.

NOTES:

<b>RESTRICTED &amp; CONFIDENTIAL</b> CONFIDENTIAL PROPERTY OF DANIELS MANUFACTURING CORP. NOT TO BE DISCLOSED TO OTHERS, REPRODUCED OR USED FOR ANY OTHER PURPOSE, EXCEPT AS AUTHORIZED IN WRITING BY DANIELS MANUFACTURING. MUST BE RETURNED TO DANIELS MANUFACTURING CORP. ON COMPLETION OF ORDER OR OTHER PURPOSE FOR WHICH LENT.	MATERIAL	ITEM	PART NO.	QTY.	DESCRIPTION/REMARKS
	HEAT TREAT	DRN.	J. JOYCE	DATE	 DANIELS MANUFACTURING CORP. ORLANDO, FLORIDA CAGE 11851
		CHK'D.	RRR	DATE	
	FINISH	APP'D.	DATE	TITLE	
APP'D.		DATE	CRIMP TOOL ENVELOPE DRAWING		
DO NOT SCALE DRAWING		NOTE: THIS DRAWING IS AN OUTLINE DRAWING OF THE RESPECTIVE DMC PART NUMBER INDICATED. ACTUAL DMC PART NUMBER IS DRAWING NUMBER WITHOUT THE "-ENV" SUFFIX.		WHERE USED: SIZE B SCALE NTS CAD P/N GMT202-ENV SHEET OF 1 1	
		POSTING		DWG. NO. GMT202-ENV REV. 5	