

REVISIONS				
REV. SYM.	E.C.O. NUMBER	DESCRIPTION	BY DATE	APP'D DATE
1		ORIGINAL RELEASE	JMC 10-7-99	JWJ 10-7-99
2		RUBBER PAD P/N WAS GRP-008	JWJ 2/2/00	RRR 2/2/00

**UNCONTROLLED DOCUMENT  
WILL NOT BE UPDATED**

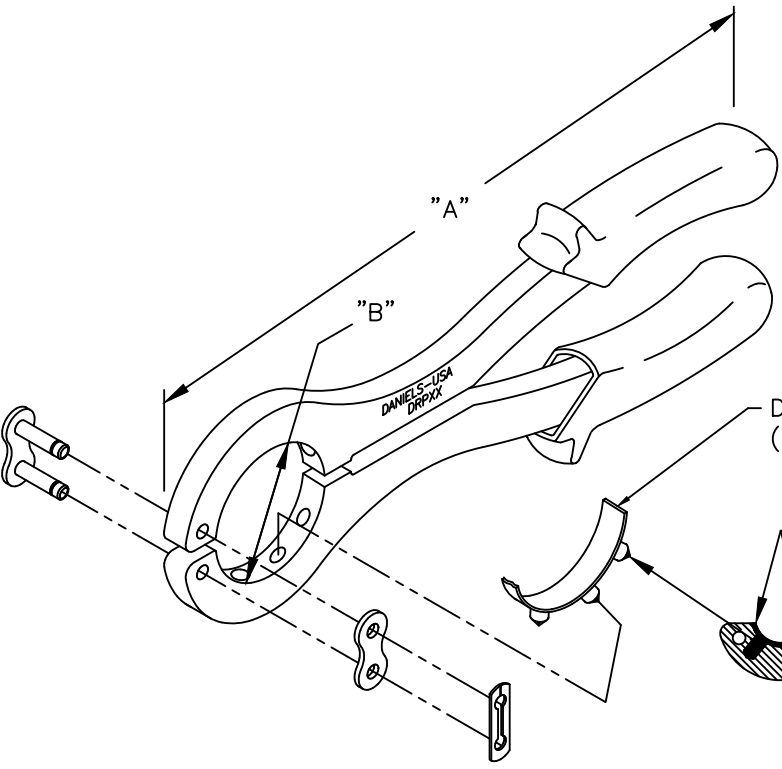

DRP-078R RUBBER PAD (RED)  
(.085" THICK X 4-1/4" LONG)

PLACE RUBBER PAD PINS IN TOOL  
FRAME HOLES AND TRIM PAD EVEN  
WITH TOOL FRAME ENDS

P/N	SHELL SIZE	"A"	ø"B"
DRP8	08/09	7 1/2	.617
DRP10	10/11	7 1/2	.734
DRP12	12/13	7 1/2	.848
DRP14	14/15	7 1/2	.954
DRP16	16/17	7 1/2	1.112
DRP18	18/19	8 1/2	1.198
DRP20	20/21	8 1/2	1.323
DRP22	22/23	8 1/2	1.448
DRP24	24/25	8 1/2	1.573
DRP26	26	8 1/2	1.655
DRP28	28	8 1/2	1.969

<p><b>RESTRICTED &amp; CONFIDENTIAL</b></p> <p>CONFIDENTIAL PROPERTY OF DANIELS MANUFACTURING CORP. NOT TO BE DISCLOSED TO OTHERS, REPRODUCED OR USED FOR ANY OTHER PURPOSE, EXCEPT AS AUTHORIZED IN WRITING BY DANIELS MANUFACTURING. MUST BE RETURNED TO DANIELS MANUFACTURING CORP. ON COMPLETION OF ORDER OR OTHER PURPOSE FOR WHICH LENT.</p>	MATERIAL	ITEM	PART NO.	QTY.	DESCRIPTION/REMARKS	
	HEAT TREAT	DRN.	JMC	DATE	10-7-99	
		CHK'D.	JWJ	DATE	10-7-99	
	FINISH	APP'D.		DATE		<p><b>DMC</b> DANIELS MANUFACTURING CORP. ORLANDO, FLORIDA CAGE 11851</p> <p>TITLE BACK SHELL PLIERS ENVELOPE DRAWING</p>
APP'D.			DATE			
DO NOT SCALE DRAWING	NOTE:		THIS DRAWING IS AN OUTLINE DRAWING OF THE RESPECTIVE DMC PART NUMBER INDICATED. ACTUAL DMC PART NUMBER IS DRAWING NUMBER WITHOUT THE "-ENV" SUFFIX.		WHERE USED:	
	SIZE	B	SCALE	NTS	CAD P/N	
	POSTING		DWG. NO.	DRP-ENV	SHEET	OF
					1	1
					REV.	2