

UNCONTROLLED DOCUMENT  
WILL NOT BE UPDATED

| REV. SYM. |  | E.C.O. NUMBER |  | REVISIONS       |                  |
|-----------|--|---------------|--|-----------------|------------------|
| 3         |  |               |  | DESCRIPTION     | BY DATE          |
|           |  |               |  | ADDED 67-008-01 | K. KOONS 1.23.08 |

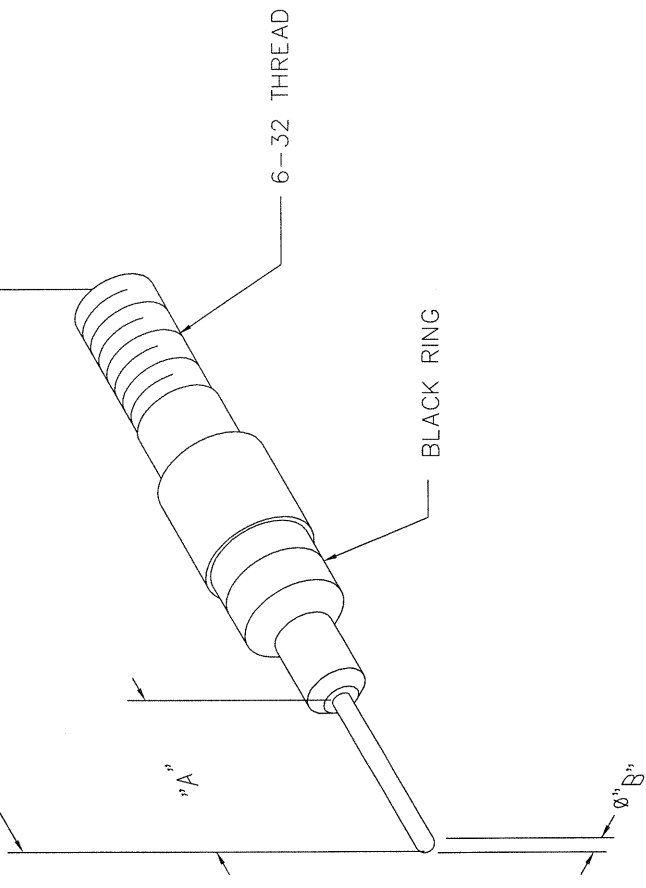

|           |      |      |       |        |
|-----------|------|------|-------|--------|
| 67-026-01 | .525 | .024 | 1.400 | GREEN  |
| 67-024-01 | .525 | .020 | 1.400 | GOLD   |
| 67-023-01 | .466 | .026 | 1.355 | BLACK  |
| 67-022-01 | .466 | .031 | 1.350 | COPPER |
| 67-020-01 | .525 | .040 | 1.405 | RED    |
| 67-016-01 | .488 | .064 | 1.375 | BLUE   |
| 67-012-01 | .675 | .094 | 1.565 | YELLOW |
| 67-008-01 | .752 | .130 | 1.500 | RED    |
| PART NO.  | "A"  | "B"  | "C"   | COLOR  |

| RESTRICTED & CONFIDENTIAL   |  | MATERIAL   |  | ITEM   |     | PART NO.   |         | QTY.        |  | DESCRIPTION/REMARKS   |  |
|---|--|------------|--|--------|-----|--|---------|-------------|--|---|--|
| CONFIDENTIAL PROPERTY OF DANIELS MANUFACTURING CORP. NOT TO BE DISCLOSED TO OTHERS, REPRODUCED OR USED FOR ANY OTHER PURPOSE, EXCEPT AS AUTHORIZED IN WRITING BY DANIELS MANUFACTURING. MUST BE RETURNED TO DANIELS MANUFACTURING CORPORATION ON ORDER OR OTHER PURPOSE FOR WHICH LENT. |  | HEAT TREAT |  | DRN.   | JMC | DATE   | 2-11-00 |             |  | <b>DMC</b><br>DANIELS MANUFACTURING CORP.<br>ORLANDO, FLORIDA<br>CAGE 11851                                     |  |
|   |  | FINISH     |  | CHK'D. | JWJ | DATE   | 2-11-00 |             |  |   |  |
|   |  |            |  | APP'D. |     | DATE   |         |             |  |   |  |
|   |  |            |  | APP'D. |     | DATE   |         |             |  |   |  |
| DO NOT SCALE DRAWING  |  |            |  | NOTE:  |     | THIS DRAWING IS AN OUTLINE DRAWING OF THE RESPECTIVE DMC PART NUMBER INDICATED. ACTUAL DMC PART NUMBER IS DRAWING PART NUMBER WITH SUFFIX "ENV". |         | WHERE USED: |  | TITLE: TIP, SOCKET RETENTION TESTER ENVELOPE DRAWING<br>SCALE: B NTS<br>CAD P/N: 67-XXX-01-ENV<br>SHEET OF: 1 1 |  |
|   |  |            |  |        |     |  |         | POSTING     |  | DWG. NO. 67-XXX-01-ENV<br>REV. 3  |  |