

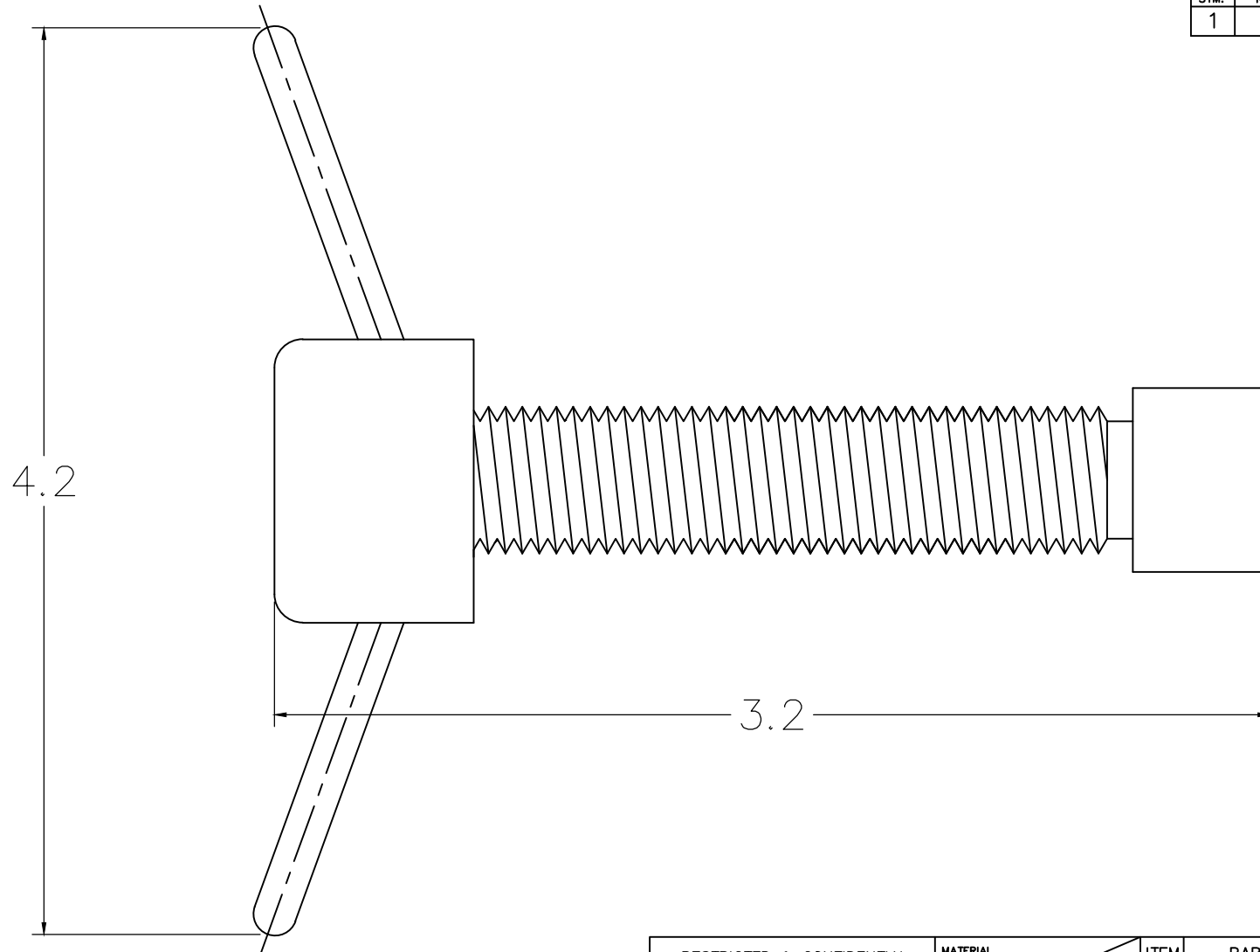

| REVISIONS | | | | |
|-----------|---------------|------------------|---------------------|----------------|
| REV. SYM. | E.C.O. NUMBER | DESCRIPTION | BY DATE | APP'D DATE |
| 1 | | ORIGINAL RELEASE | K. KOONS 3/24/03 | RRR 3/24/03 |



**UNCONTROLLED DOCUMENT
WILL NOT BE UPDATED**

NOTES:

| | | | | | | | | |
|---|------------|---|-----------------|-------------|--|------------------------|------------|---------|
| RESTRICTED & CONFIDENTIAL CONFIDENTIAL PROPERTY OF DANIELS MANUFACTURING CORP. NOT TO BE DISCLOSED TO OTHERS, REPRODUCED OR USED FOR ANY OTHER PURPOSE, EXCEPT AS AUTHORIZED IN WRITING BY DANIELS MANUFACTURING. MUST BE RETURNED TO DANIELS MANUFACTURING CORP. ON COMPLETION OF ORDER OR OTHER PURPOSE FOR WHICH LENT. | MATERIAL | ITEM | PART NO. | QTY. | DESCRIPTION/REMARKS | | | |
| | HEAT TREAT | DRN. J. JOYCE | DATE 3/24/03 | |  DANIELS MANUFACTURING CORP. ORLANDO, FLORIDA CAGE 11851 | | | |
| | FINISH | CHK'D. RRR | DATE 3/24/03 | | | | | |
| DO NOT SCALE DRAWING | | APP'D. | DATE | TITLE | CLAMP ASSEMBLY ENVELOPE DRAWING | | | |
| | | NOTE: | DATE | WHERE USED: | | | | |
| | | THIS DRAWING IS AN OUTLINE DRAWING OF THE RESPECTIVE DMC PART NUMBER INDICATED. ACTUAL DMC PART NUMBER IS DRAWING NUMBER WITHOUT THE "-ENV" SUFFIX. | | SIZE B | SCALE NTS | CAD P/N 15-0080-ENV | SHEET 1 | OF 1 |
| | | | | POSTING | DWG. NO. 15-0080-ENV | REV. 1 | | |